



DEPARTMENT OF REGULATORY AND ECONOMIC RESOURCES (RER)  
BOARD AND CODE ADMINISTRATION DIVISION

MIAMI-DADE COUNTY  
PRODUCT CONTROL SECTION  
11805 SW 26 Street, Room 208  
Miami, Florida 33175-2474  
T (786) 315-2590 F (786) 315-2599

[www.miamidade.gov/economy](http://www.miamidade.gov/economy)

**NOTICE OF ACCEPTANCE (NOA)**

**Shutter Tech, Inc.**  
7485 West 2<sup>nd</sup> Court  
Hialeah, Florida 33014

**SCOPE:**

This NOA is being issued under the applicable rules and regulations governing the use of construction materials. The documentation submitted has been reviewed and accepted by Miami-Dade County RER- Product Control Section to be used in Miami Dade County and other areas where allowed by the Authority Having Jurisdiction (AHJ).

This NOA shall not be valid after the expiration date stated below. The Miami-Dade County Product Control Section (In Miami Dade County) and/or the AHJ (in areas other than Miami Dade County) reserve the right to have this product or material tested for quality assurance purposes. If this product or material fails to perform in the accepted manner, the manufacturer will incur the expense of such testing and the AHJ may immediately revoke, modify, or suspend the use of such product or material within their jurisdiction. RER reserves the right to revoke this acceptance, if it is determined by Miami-Dade County Product Control Section that this product or material fails to meet the requirements of the applicable building code.

This product is approved as described herein, and has been designed to comply with the High Velocity Hurricane Zone of the Florida Building Code.

**DESCRIPTION: Maximum Impact 0.031” (min.) Steel Storm Panels Shutter**

**APPROVAL DOCUMENT:** Drawing No. 98001, titled “Maximum Impact .031 Steel Storm Panel”, sheets 1 through 7 of 7, prepared by Ramms Engineering, Inc., dated January 10, 1998, last revision dated July 18, 2017, signed and sealed by Robert S. Monsour, P.E., bearing the Miami-Dade County Product Control Revision stamp with the Notice of Acceptance number & the expiration date by Miami-Dade County Product Control Section.

**MISSILE IMPACT RATING: Large and Small Missile Impact Resistant**

**LABELING:** Each panel shall bear a permanent label with the manufacturer's name or logo, city, state, the following statement: "Miami-Dade County Product Control Approved", and NOA number, per TAS-201, TAS-202, and TAS-203, unless otherwise noted herein.

**RENEWAL** of this NOA shall be considered after a renewal application has been filed and there has been no change in the applicable building code negatively affecting the performance of this product.

**TERMINATION** of this NOA will occur after the expiration date or if there has been a revision or change in the materials, use, and/or manufacture of the product or process. Misuse of this NOA as an endorsement of any product, for sales, advertising or any other purposes shall automatically terminate this NOA. Failure to comply with any section of this NOA shall be cause for termination and removal of NOA.

**ADVERTISEMENT:** The NOA number preceded by the words Miami-Dade County, Florida, and followed by the expiration date may be displayed in advertising literature. If any portion of the NOA is displayed, then it shall be done in its entirety.

**INSPECTION:** A copy of this entire NOA shall be provided to the user by the manufacturer or its distributors and shall be available for inspection at the job site at the request of the Building Official.

This NOA revises NOA #16-1222.07 and consists of this page 1, evidence submitted pages E-1, E-2, E-3, E-4, E-5 & E-6 as well as approval document mentioned above.

The submitted documentation was reviewed by **Helmy A. Makar, P.E., M.S.**



*Helmy A. Makar*  
01/04/2018

NOA No. 17-1114.18  
Expiration Date: 03/22/2022  
Approval Date: 01/04/2018  
Page 1

**NOTICE OF ACCEPTANCE: EVIDENCE SUBMITTED**

**1. EVIDENCE SUBMITTED UNDER PREVIOUS APPROVAL #98-0304.03**

**A. DRAWINGS:**

1. *Drawing No. 98001, titled "24 ga. maximum impact storm panel", prepared by Ramms Engineering, Inc., dated January 10, 1998, last revised on August 14, 1998, sheets 1 through 7 of 7, signed and sealed by Robert S. Monsour, P.E.*

**B. TESTS:**

1. *Test report on Large Missile Impact Test, Cyclic Wind Pressure Test and Uniform Static Air Pressure Test of a 24 ga. steel storm panels, prepared by Construction Testing Corporation, Report No. 98-003, dated 02/27/98, signed and sealed by Christopher G. Tyson, P.E.*
2. *Test report on Large Missile Impact Test, Cyclic Wind Pressure Test and Uniform Static Air Pressure Test of aluminum storm panels, prepared by Construction Testing Corporation, Report No. 98-005, dated 05/21/98, signed and sealed by Christopher G. Tyson, P.E.*

**C. CALCULATIONS:**

1. *Comparative Analysis, dated February 18, 1998, pages 1 through 4, prepared by Ramms Engineering, Inc., signed and sealed by Robert S. Monsour, P.E.*
2. *Revised calculations for Comparative Analysis and Anchor Spacing Analysis, dated June 4, 1998, pages 1 through 49, prepared by Ramms Engineering, Inc., signed and sealed by Robert S. Monsour, P.E.*
3. *Revised calculations for Anchor Spacing Analysis, dated August 3, 1998, pages 1 through 35, prepared by Ramms Engineering, Inc., signed and sealed by Robert S. Monsour, P.E.*
4. *Revised calculations for Anchor Spacing Analysis, dated September 1, 1998, pages 1 through 94, prepared by Ramms Engineering, Inc., signed and sealed by Robert S. Monsour, P.E.*

**D. MATERIAL CERTIFICATION:**

1. *Mill Certified Inspection Report dated December 10, 1997, prepared by Kieh Co., for steel panel.*
2. *Certified Tensile Test Report by Certified Testing Laboratories, Report No. CTL-076D, dated 02/04/98, signed and sealed by Ramesh Patel, P.E.*

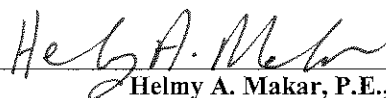

Helmy A. Makar, P.E., M.S.  
Product Control Section Supervisor  
NOA No. 17-1114.18  
Expiration Date: 03/22/2022  
Approval Date: 01/04/2018

**Shutter Tech, Inc.**

**NOTICE OF ACCEPTANCE: EVIDENCE SUBMITTED**

**2. EVIDENCE SUBMITTED UNDER PREVIOUS APPROVAL #00-1207.03**

**A. DRAWINGS:**

1. *Drawing No. 98001, titled "24 ga. maximum impact storm panel", prepared by Ramms Engineering, Inc., dated 01/10/1998, last revised on 12/15/2000, sheets 1 and 5 of 7, 08/14/1998, sheets 2, 3, 6, and 7 of 7, and on 12/04/2000, sheet 4 of 7, all signed and sealed by Robert S. Monsour, P.E. on 12/22/2000.*

**B. TESTS:**

1. *None.*

**C. CALCULATIONS:**

1. *None.*

**D. MATERIAL CERTIFICATION:**

1. *None.*

**3. EVIDENCE SUBMITTED UNDER PREVIOUS APPROVAL #01-0205.01**

**A. DRAWINGS:**

1. *Drawing No. 98001, titled "24 ga. maximum impact storm panel", prepared by Ramms Engineering, Inc., dated January 10, 1998, last revised on January 17, 2001, signed and sealed by Robert S. Monsour, P.E. on January 29, 2001.*

**B. TESTS:**

1. *None.*

**C. CALCULATIONS:**

1. *None.*

**D. MATERIAL CERTIFICATION:**

1. *None.*

**4. EVIDENCE SUBMITTED UNDER PREVIOUS APPROVAL # 01-1224.07**

**A. DRAWINGS**

1. *Drawing No. 98001, titled " Maximum Impact Storm Panel ", sheets 1 through 7 of 7, prepared by Ramms Engineering, Inc., dated 01/10/1998, last revision dated 09/09/2002 signed and sealed by Robert S. Monsour, P.E.*

**B. TESTS**

1. *Test reports on Large Missile Impact Test per SFBC, PA 201-94 along with installation diagram of Steel Storm Panel Shutter, prepared by American Test Lab of South Florida, Test Report No. 0 502.02-02, dated 05/09/2002, signed and sealed by William R. Mehner, P.E.*

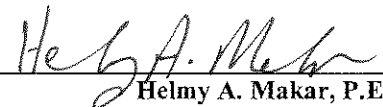

Helmy A. Makar, P.E., M.S.  
Product Control Section Supervisor  
NOA No. 17-1114.18  
Expiration Date: 03/22/2022  
Approval Date: 01/04/2018

**Shutter Tech, Inc.**

**NOTICE OF ACCEPTANCE: EVIDENCE SUBMITTED**

2. *Addendum to Test reports on Large Missile Impact Test per PA 201-94 of Steel Storm Panel Shutter, prepared by American Test Lab of South Florida, Report No. 0 502.02-02, dated 07/09/2002, signed & sealed by William R. Mehner, P.E.*
- C. CALCULATIONS**
  1. *Comparative analysis, prepared by prepared by Ramms Engineering, Inc., dated January 14, 2002, signed and sealed by Robert S. Monsour, P.E.*
- D. MATERIAL CERTIFICATIONS**
  1. *None.*
- 5. EVIDENCE SUBMITTED UNDER PREVIOUS APPROVAL # 06-0110.04**
  - A. DRAWINGS**
    1. *Drawing No. 98001, titled " Maximum Impact Storm Panel ", sheets 1 through 7 of 7, prepared by Ramms Engineering, Inc., dated January 10, 1998, last revision dated January 06, 2006, signed and sealed by Robert S. Monsour, P.E.*
  - B. TESTS**
    1. *None.*
  - C. CALCULATIONS**
    1. *Revised calculations for Anchor Spacing, dated 01/06/2006, 88 pages, prepared by Ramms Engineering, Inc., signed & sealed by Robert S. Monsour, P.E.*
  - D. QUALITY ASSURANCE**
    1. *By Miami-Dade County Building Code Compliance Office.*
  - E. MATERIAL CERTIFICATIONS**
    1. *None.*
- 6. EVIDENCE SUBMITTED UNDER PREVIOUS APPROVAL #11-0304.01**
  - A. DRAWINGS**
    1. *Drawing No. 98001, titled " Maximum Impact Storm Panel ", sheets 1 through 7 of 7, prepared by Ramms Engineering, Inc., dated January 10, 1998, last revision dated January 06, 2006, signed and sealed by Robert S. Monsour, P.E.*
  - B. TESTS**
    1. *None. One year renewal to give manufacturer time to submit a verification test.*
  - C. CALCULATIONS**
    1. *None.*

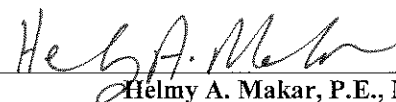

Helmy A. Makar, P.E., M.S.  
Product Control Section Supervisor  
NOA No. 17-1114.18  
Expiration Date: 03/22/2022  
Approval Date: 01/04/2018

**Shutter Tech, Inc.**

**NOTICE OF ACCEPTANCE: EVIDENCE SUBMITTED**

**D. QUALITY ASSURANCE**

1. *By Miami-Dade County Building and Neighborhood Compliance Department.*

**E. MATERIAL CERTIFICATIONS**

1. *None.*

**F. OTHERS**

1. *Conformance letter from Ramms Engineering, Inc., dated March 24, 2011, certifying compliance with the Florida Building Code, 2007 Edition, singed and sealed by Robert S. Monsour, P.E.*

**7. EVIDENCE SUBMITTED UNDER PREVIOUS APPROVAL # 12-0320.26**

**A. DRAWINGS**

1. *Drawing No. 98001, titled " Maximum Impact Storm Panel ", sheets 1 through 7 of 7, prepared by Ramms Engineering, Inc., dated January 10, 1998, last revision dated January 06, 2006, signed and sealed by Robert S. Monsour, P.E.*

**B. TESTS**

1. *Test report on Large Missile Impact, Cyclic Wind Pressure and Uniform Static Air Pressure Test of a 24 ga. steel storm panels, prepared by Blackwater Testing, Inc., Report No. AG-11-001, dated 03/12/12, signed and sealed by yamil G. Kuri, P.E.*

**C. CALCULATIONS**

1. *None.*

**D. QUALITY ASSURANCE**

1. *By Miami-Dade County Department of Permitting, Environment, and Regulatory Affairs.*

**E. MATERIAL CERTIFICATIONS**

1. *Certified report of Chemical Analysis and mechanical tests by the techs.*

**F. OTHERS**

1. *Conformance letter from Ramms Engineering, Inc., dated March 20, 2012, certifying compliance with the Florida Building Code, 2010 Edition, singed and sealed by Robert S. Monsour, P.E.*

**8. EVIDENCE SUBMITTED UNDER PREVIOUS APPROVAL # 14-0127.02**

**A. DRAWINGS**

1. *Drawing No. 98001, titled "Maximum Impact .031 Steel Storm Panel", sheets 1 through 7 of 7, prepared by Ramms Engineering, Inc., dated 01/10/1998, last revision dated 01/16/2014, signed and sealed by Robert S. Monsour, P.E.*

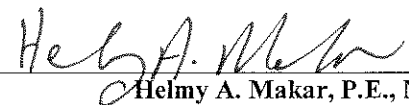

Helmy A. Makar, P.E., M.S.  
Product Control Section Supervisor

NOA No. 17-1114.18

Expiration Date: 03/22/2022

Approval Date: 01/04/2018

**Shutter Tech, Inc.**

**NOTICE OF ACCEPTANCE: EVIDENCE SUBMITTED**

**B. TESTS**

1. *None.*

**C. CALCULATIONS**

1. *None.*

**D. QUALITY ASSURANCE**

1. *By Miami-Dade County Department of Regulatory and Economic Resources.*

**E. MATERIAL CERTIFICATIONS**

1. *None.*

**F. OTHERS**

1. *Asset Purchase Agreement.*

**9. EVIDENCE SUBMITTED UNDER PREVIOUS APPROVAL # 15-0714.23**

**A. DRAWINGS**

1. *Drawing No. 98001, titled "Maximum Impact .031 Steel Storm Panel", sheets 1 through 7 of 7, prepared by Ramms Engineering, Inc., dated January 10, 1998, last revision dated 09/29/2015, signed and sealed by Robert S. Monsour, P.E.*

**B. TESTS**

1. *None.*

**C. CALCULATIONS**

1. *None.*

**D. QUALITY ASSURANCE**

1. *By Miami-Dade County Department of Regulatory and Economic Resources.*

**E. MATERIAL CERTIFICATIONS**

1. *None.*

**F. OTHERS**

1. *FBC, 2014 Edition compliance letter prepared by Ramms Engineering, Inc., dated June 26, 2015, signed & sealed by Robert Monsour, P.E.*

**10. EVIDENCE SUBMITTED UNDER PREVIOUS APPROVAL # 16-1222.07**

**A. DRAWINGS**

1. *None.*

**B. TESTS**

1. *None.*

  
Helmy A. Makar, P.E., M.S.

Product Control Section Supervisor

NOA No. 17-1114.18

Expiration Date: 03/22/2022

Approval Date: 01/04/2018

**Shutter Tech, Inc.**

**NOTICE OF ACCEPTANCE: EVIDENCE SUBMITTED**

**C. CALCULATIONS**

1. *None.*

**D. QUALITY ASSURANCE**

1. *By Miami-Dade County Department of Regulatory and Economic Resources.*

**E. MATERIAL CERTIFICATIONS**

1. *None.*

**11. NEW EVIDENCE SUBMITTED**

**A. DRAWINGS**

1. *Drawing No. 98001, titled "Maximum Impact .031 Steel Storm Panel", sheets 1 through 7 of 7, prepared by Ramms Engineering, Inc., dated January 10, 1998, last revision dated July 18, 2017, signed and sealed by Robert S. Monsour, P.E.*

**B. TESTS**

1. *None.*

**C. CALCULATIONS**

1. *None.*

**D. QUALITY ASSURANCE**

1. *By Miami-Dade County Department of Regulatory and Economic Resources.*

**E. MATERIAL CERTIFICATIONS**

1. *None.*

**F. OTHERS**

1. *FBC, 2017 Edition compliance letter prepared by Ramms Engineering, Inc., dated July 18, 2017, signed & sealed by Robert Monsour, P.E.*

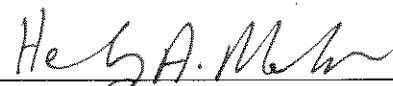

Helmy A. Makar, P.E., M.S.  
Product Control Section Supervisor  
NOA No. 17-1114.18  
Expiration Date: 03/22/2022  
Approval Date: 01/04/2018

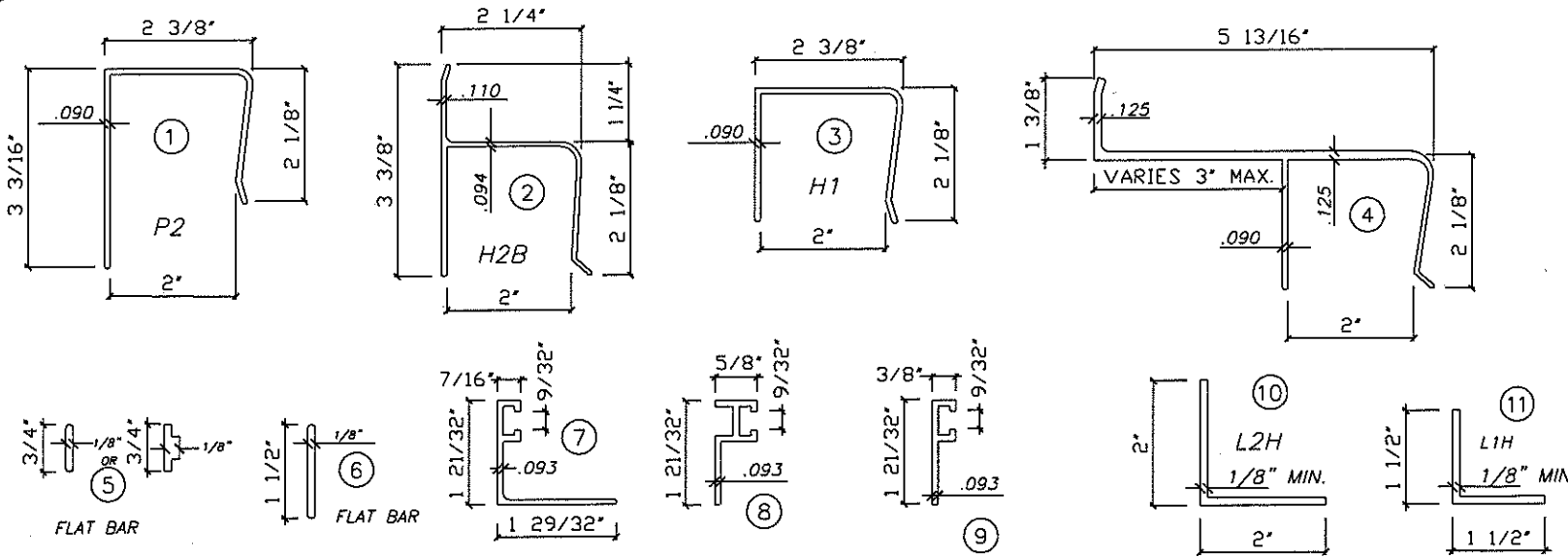

VARIOUS TYPES OF F-TRACK NOT SHOWN

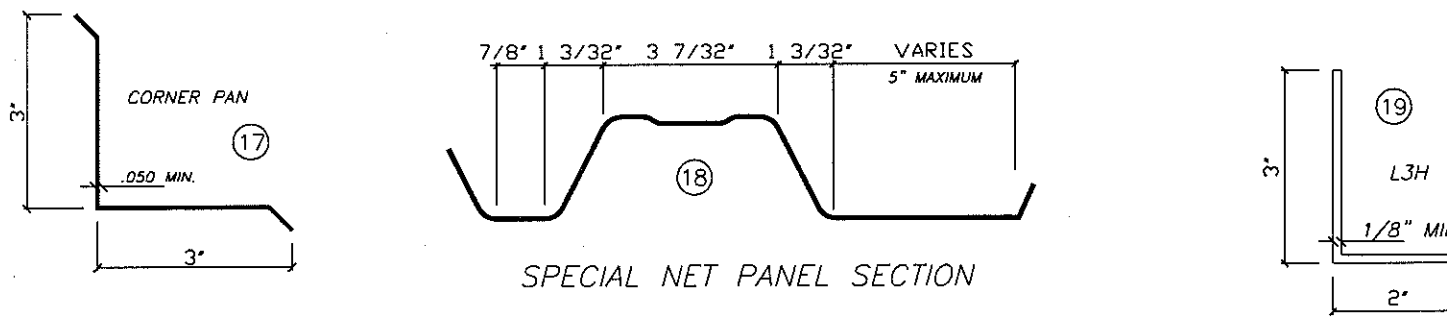
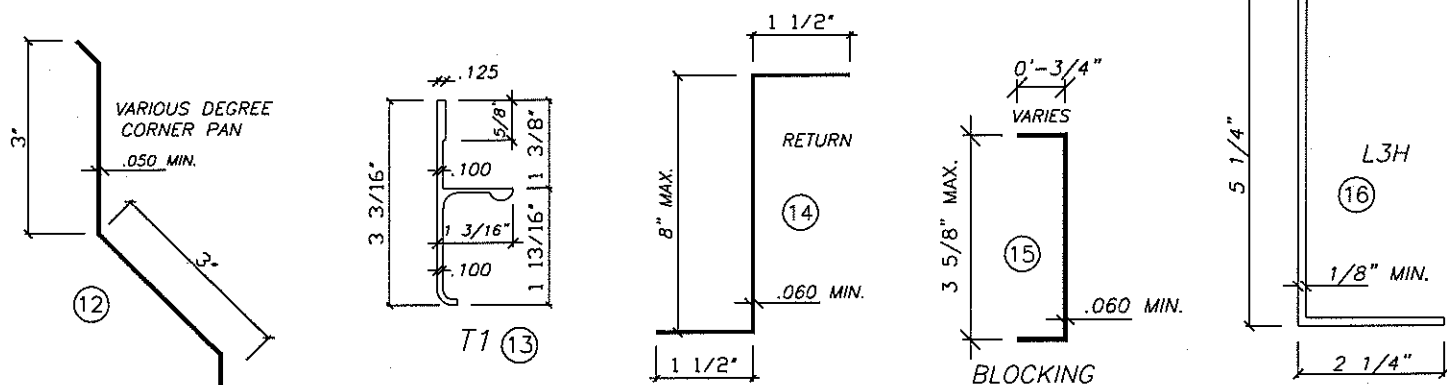

SPECIAL NET PANEL SECTION

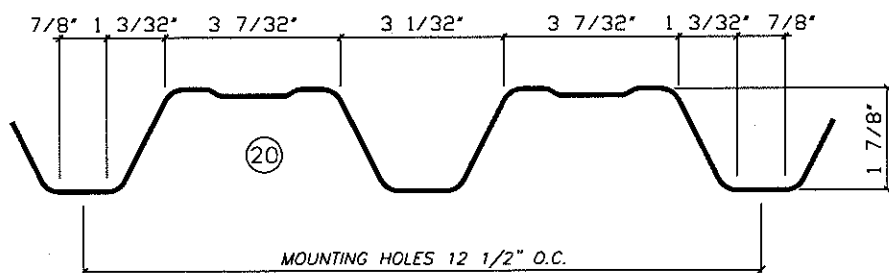

CROSS SECTIONS

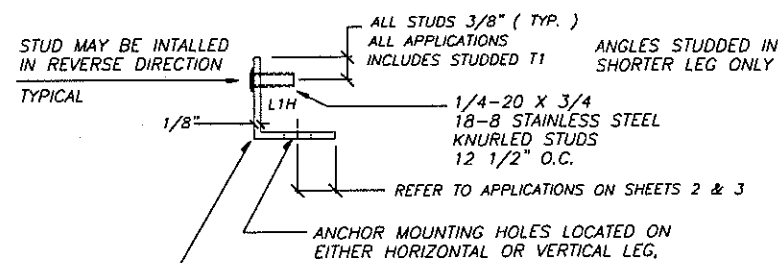

STUDED ANGLE DETAIL

1/8" x 1 1/2" FLAT STUDED STRAP MAY BE USED IN PLACE OF ANGLE

COMPLIES WITH:  
FLORIDA BUILDING CODE SIXTH EDITION (2017) (H.V.H.Z.)  
TESTED TO TAS201, TAS202 AND TAS203

**24GA .031**  
**(H.V.H.Z.)**

**DESIGN CRITERIA:**

WIND LOADS TO BE CALCULATED AS PER ASCE 7-10

NO INCREASE IN ALLOWABLE STRESS WAS USED IN THE DESIGN OF THIS PRODUCT

**GENERAL NOTES:**

ALL ALUMINUM EXTRUSIONS TO BE ALLOY 6063-T6 OR EQUAL

STORM PANELS SHALL BE:

**24 GAUGE STEEL, ASTM A653 SQ GRADE E MIN. Fy = 90 K.S.I. MINIMUM VALUE WITH .031 MINIMUM THICKNESS**

HOT DIP COATED. WITH A NOMINAL WIDTH OF 12 1/2"

THE STORM PANEL SHUTTER MAY BE INSTALLED VERTICALLY OR HORIZONTALLY, IN ACCORDANCE TO THE DETAILED SPECIFICATIONS HEREIN.

PANELS MAY BE NOTCHED OR MITERED TO ACCOMMODATE AN OBSTRUCTION  
PANELS MAY HAVE A RIPPLED SURE GRIP OR A HEMMED EDGE

ANCHORAGE OF THE SHUTTER SYSTEM TO CONCRETE OR MASONRY SHALL CONSIST OF THE FOLLOWING OR EQUAL WITH MINIMUM ULTIMATE LOAD VALUES SHOWN

- 1/4" DIA. RAWL LOK/BOLT ANCHOR ( SLEEVED DRIVE ANCHOR )  
MIN. TENSILE 1190 - MIN. SHEAR 1520 - 1 1/8" MIN. EMBED. IN CONCRETE  
MIN. TENSILE 1200 - MIN. SHEAR 1270 - 1 1/8" MIN. EMBED. IN MASONRY
- 1/4-20 RAWL CALK-IN ANCHOR ( MACHINE SCREW ANCHOR ) WITH 1/4-20 BOLTS  
MIN. TENSILE 1870 - MIN. SHEAR 1730 - 7/8" MIN. EMBED. IN CONCRETE  
MIN. TENSILE 880 - MIN. SHEAR 1340 - 7/8" MIN. EMBED. IN MASONRY
- 1/4" PERMA-SEAL TAPPER BY RAWL ( MASONRY SCREWS VARIOUS HEAD TYPES )  
MIN. TENSILE 1520 - MIN. SHEAR 1980 - 1 1/2" MEN. EMBED. IN CONCRETE  
MIN. TENSILE 880 - MIN. SHEAR 1270 - 1 1/4" MIN. EMBED. IN MASONRY
- 1/4" ZAMAC NAILIN BY RAWL ( ZAMAC HAMMER DRIVES )  
MIN. TENSILE 980 - MIN. SHEAR 1400 - 1 3/8" MIN. EMBED. IN CONCRETE  
MIN. TENSILE 730 - MIN. SHEAR 1320 - 1 1/4" MIN. EMBED. IN MASONRY

ANCHORAGE TO WOOD CONSTRUCTION SHALL BE 1/4" STEEL LAGS OR LARGER WITH 1" MIN. THREAD PENETRATION, 1/4-20 BRASS WOOD BUSHINGS OR 1/4" ELCO PANEL MATES OR MASONRY SCREW WITH 1 7/8" MIN. THREAD PENETRATION.

REFER TO SHEETS 5, 6 & 7 OF 7 FOR ANCHOR SPACING AND MINIMUM EMBEDMENTS

IT SHALL BE THE RESPONSIBILITY OF THE CONTRACTOR TO VERIFY THE SOUNDNESS OF THE STRUCTURE TO WITHSTAND THE ADDITIONAL LOADS AND INSURE PROPER ANCHORAGE.

EACH PANEL SHALL BEAR A PERMANENT LABEL OR STAMP SHOWING  
" SHUTTER TECH, INC. HIALEAH, FL " " DADE COUNTY PRODUCT CONTROL APPROVED "

WARNING TO OWNER OR TENANT LOCATED IN EACH HEADER OR ONE PANEL OF EACH OPENING, STATING " STORM PANELS WILL NOT OFFER HURRICANE PROTECTION UNLESS ALL REINFORCING STRAPS OR BOLTS ARE PROPERLY INSTALLED, WHEN REQUIRED "

PERMANENT FASTENER COMPONENTS, EMBEDDED ANCHOR BOLTS, THREADED CONES OR METAL SHIELDS, NOT IN USE, MUST BE PROTECTED AGAINST CORROSION, CONTAMINATION AND DAMAGE AT ALL TIME.

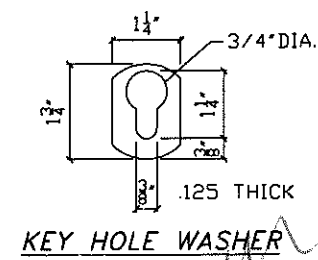

KEY HOLE WASHER

ROBERT S. MONSOUR, PE  
EB-0006024  
RAMMS ENGINEERING, INC.

BUILDING CODE COMPLIANCE

REVISIONS	BY
01/05/06	SP
01/16/14	SP
09/29/15	SP
07/18/17	SP

RAMMS ENGINEERING, INC.  
*Structural Design*  
2100 W. 76th STREET, SUITE 311  
HIALEAH, FLORIDA 33016  
EB 0006024

MAXIMUM IMPACT .031 STEEL STORM PANEL  
**SHUTTER-TECH, INC.**  
7485 W. SECOND CT. HIALEAH, FL 33014

DATE	BY
01/10/98	SEP/JRB
SCALE	SHOWN
98001	SHEET
1	7



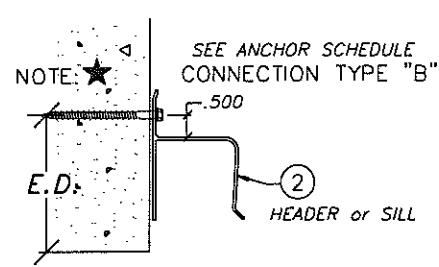

**DETAIL 1**

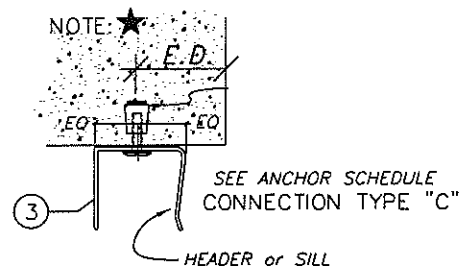

**DETAIL 2**

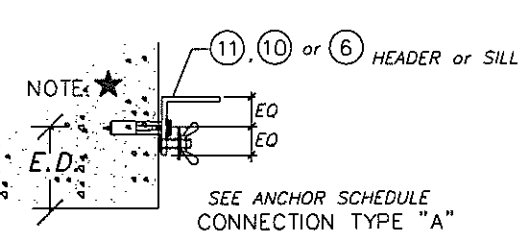

**DETAIL 3**

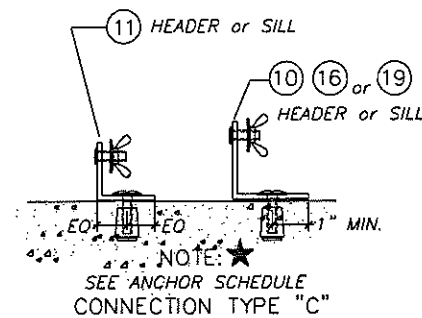

**DETAIL 4**

**MAXIMUM IMPACT STORM PANEL**

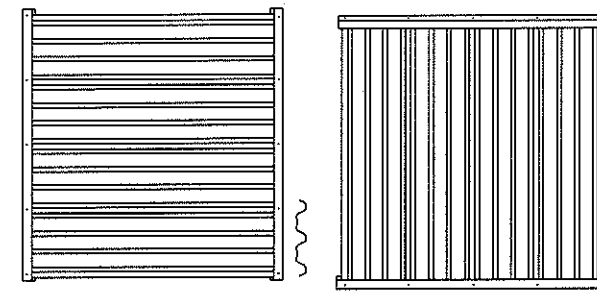

HORIZONTAL INSTALLATION ELEVATION

VERTICAL INSTALLATION ELEVATION

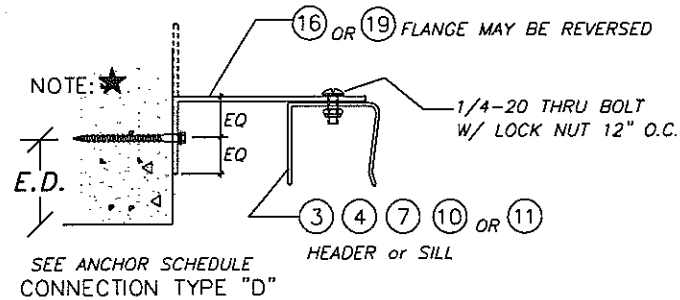

**DETAIL 5**

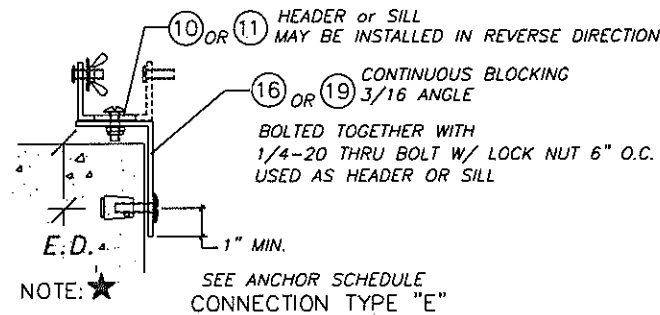

**DETAIL 6**

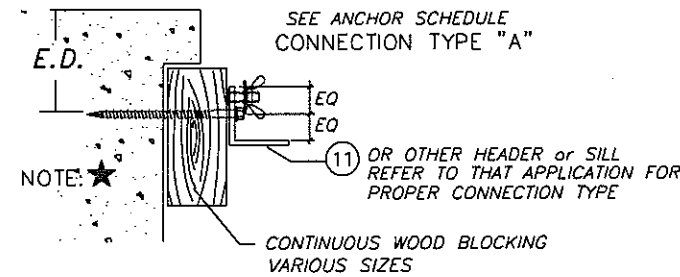

**DETAIL 7**

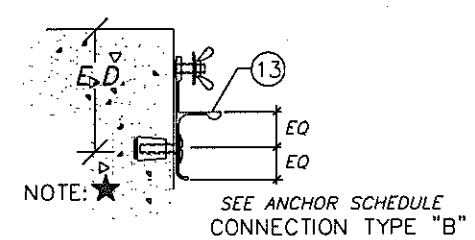

**DETAIL 8**

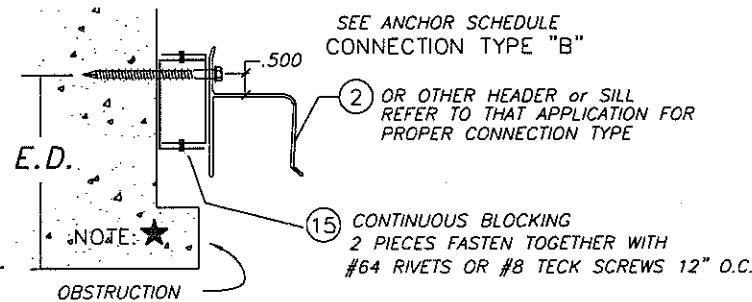

**DETAIL 9**

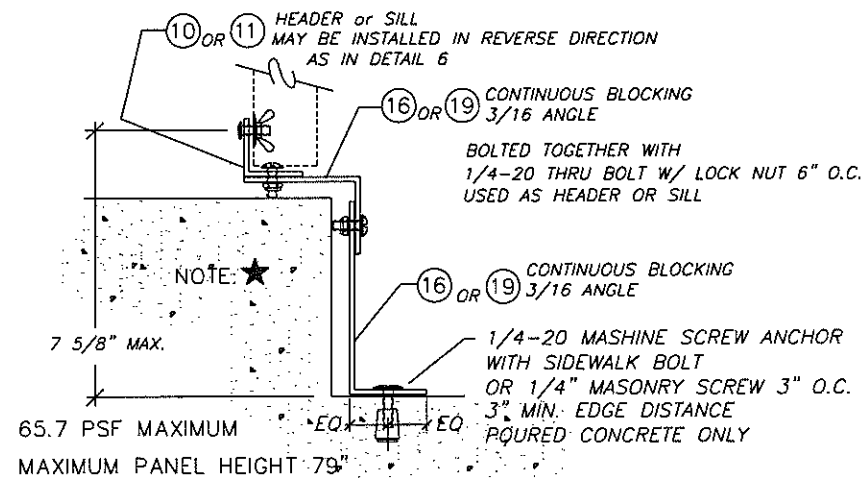

**DETAIL 10**

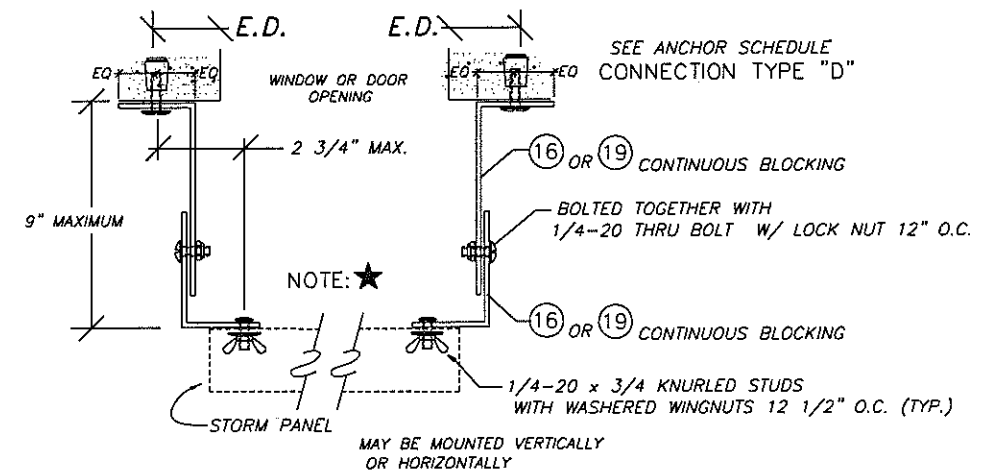

**DETAIL 11**

NOTE: ★

IT SHALL BE THE RESPONSIBILITY OF THE CONTRACTOR TO VERIFY THE SOUNDNESS OF THE STRUCTURE TO WITH STAND THE ADDITIONAL LOADS AND INSURE PROPER ANCHORAGE. SHUTTER SYSTEM MAY BE INTSALL INTO WOOD, CONCRETE, MASONRY.

WHEN ANCHORING TO WOOD, THE WOOD MUST BE A MINIMUM 2 X 4 EQUAL TO #2 SOUTHERN PINE WITH 0.55 SPECIFIC GRAVITY AND STRUCTURALLY PART OF THE FRAMING STRUCTURE OR SUCURELY ATTACHED TO FRAMING STRUCTURE

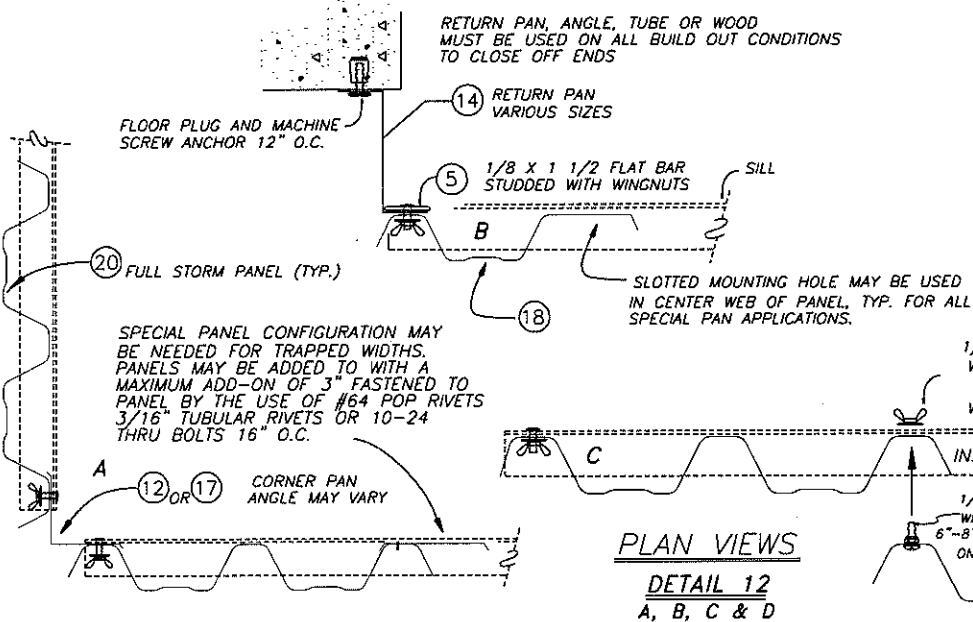

**PLAN VIEWS**  
**DETAIL 12**  
A, B, C & D

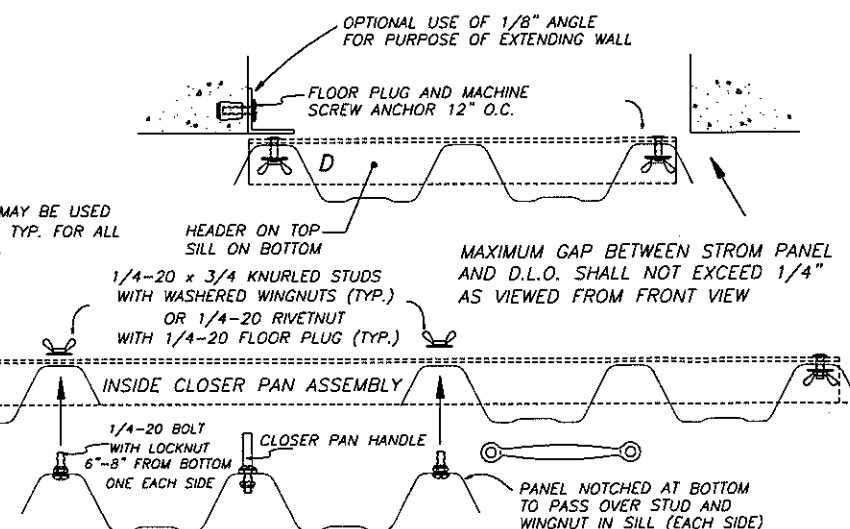

ROBERT S. MONSOUR, PE  
EB-0006024  
RAMMS ENGINEERING, INC.

PRODUCT REVISED  
as complying with the Florida  
Building Code  
Acceptance No 17-1114.18  
Expiration Date 03/22/22  
By Heba A. Monsour  
Miami Design Product Control

BUILDING CODE COMPLIANCE

REVISIONS	BY
03/20/98	SP
01/17/01	SP
01/06/06	SP
01/16/14	SP

RAMMS ENGINEERING, INC.  
Structural Design  
2100 W. 76th STREET, SUITE 311  
HALEAH, FLORIDA 33016

MAXIMUM IMPACT .031 STEEL STORM PANEL  
**SHUTTER-TECH, INC.**  
7485 W. SECOND CT. HIALEAH, FL 33014

DATE	SCALE	SHEET
SEP / JRB / RSM	01/10/98	98001
	SHOWN	
		2
		7

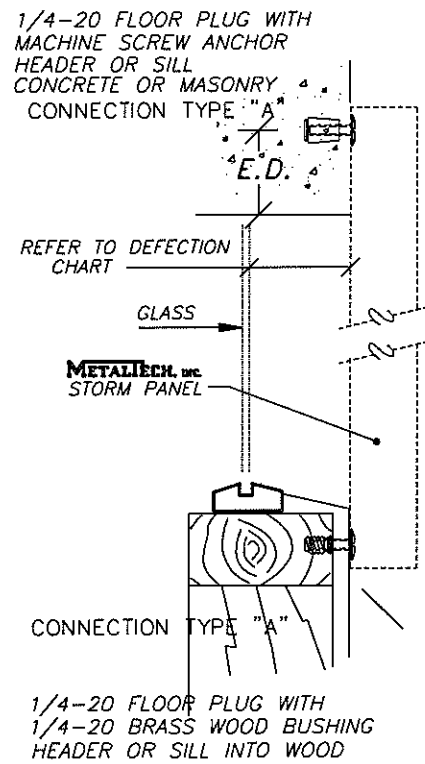

NOTE:  
THE METALTECH STORM PANEL MAY BE INSTALLED WITHOUT THE USE OF AN EXTRUDED HEADER OR SILL. THE SHUTTER MAY BE ANCHORED DIRECTLY TO THE STRUCTURE WITH THE USE OF ONE OR A COMBINATION OF DETAIL 13

NOTE:★

**DETAIL 13**

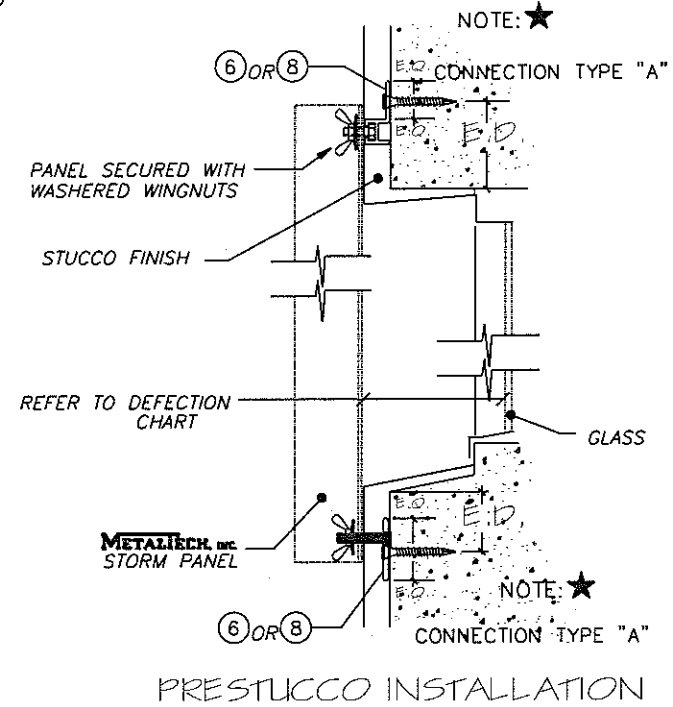
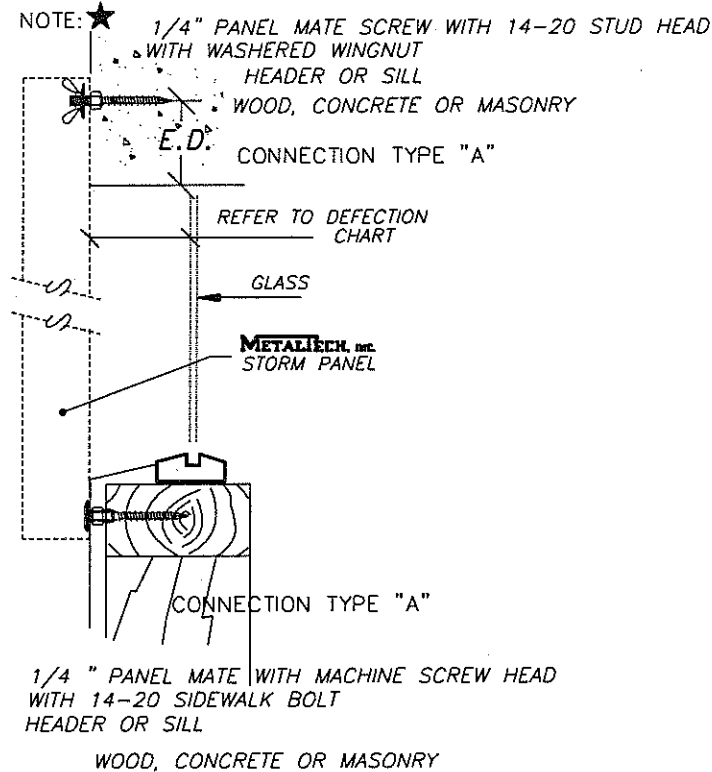

**DETAIL 14**

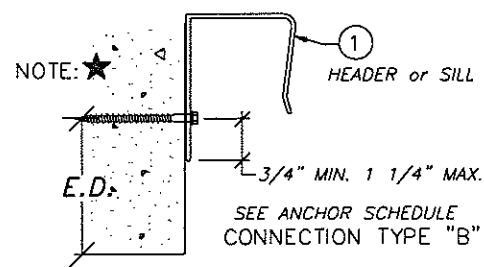

**DETAIL 15**

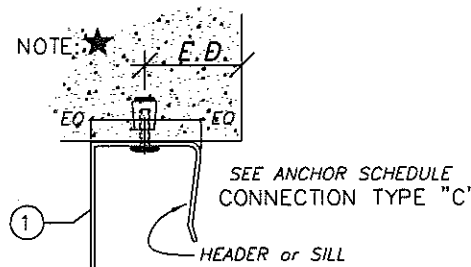

**DETAIL 16**

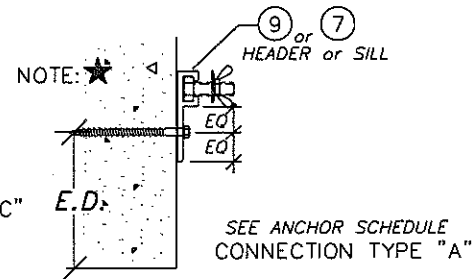

**DETAIL 17**

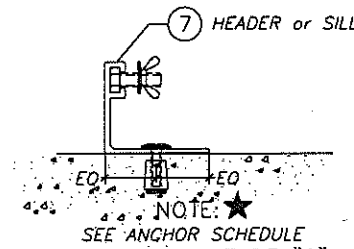

**DETAIL 18**

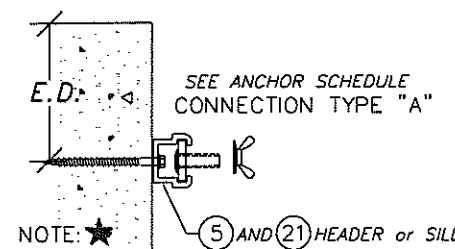

**DETAIL 19**

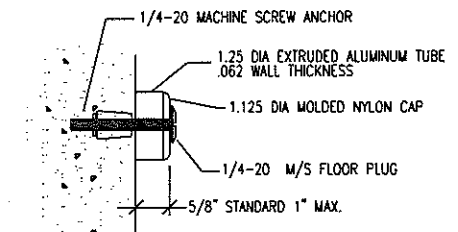

**DETAIL 20**

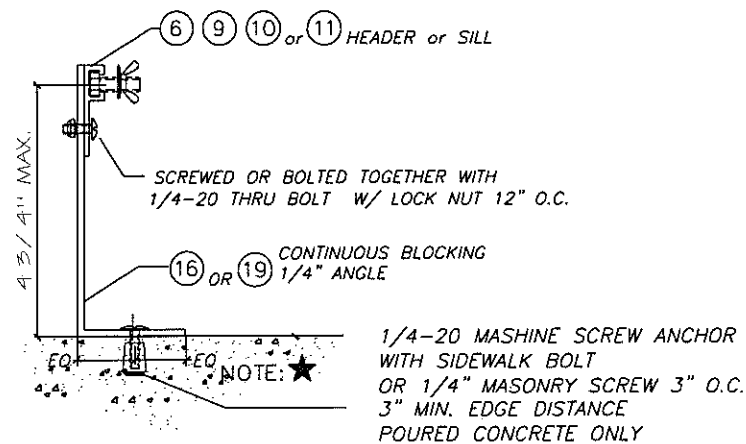

59.5 PSF MAXIMUM / PANEL HEIGHT 109" MAXIMUM

**DETAIL 21**

ADJUSTABLE HEADER OR SILL

NOTE:★

IT SHALL BE THE RESPONSIBILITY OF THE CONTRACTOR TO VERIFY THE SOUNDNESS OF THE STRUCTURE TO WITH STAND THE ADDITIONAL LOADS AND INSURE PROPER ANCHORAGE. SHUTTER SYSTEM MAY BE INTSALL INTO WOOD, CONCRETE, MASONRY.

WHEN ANCHORING TO WOOD, THE WOOD MUST BE A MINIMUM 2 X 4 EQUAL TO #2 SOUTHERN PINE WITH 0.55 SPECIFIC GRAVITY AND STRUCTURALLY PART OF THE FRAMING STRUCTURE OR SUCURELY ATTACHED TO FRAMING STRUCTURE

ROBERT S. MONSOUR, PE  
EB-0006024  
RAMMS ENGINEERING, INC.

PRODUCT REVISED as complying with the Florida Building Code Acceptance No 17-1114-18 Expiration Date 03/22/22 By: *Hesha M. Moh* Miami Product Control

BUILDING CODE COMPLIANCE

REVISIONS	BY
03/20/98	SP
01/17/01	SP
01/11/02	SP
01/06/06	SP
01/16/14	SP

RAMMS ENGINEERING, INC.  
*Structural Design*  
2100 W. 76th STREET, SUITE 311  
HIALEAH, FLORIDA 33016  
EB 0006024

MAXIMUM IMPACT .031 STEEL STORM PANEL  
**SHUTTER-TECH, INC.**  
7485 W. SECOND CT. HIALEAH, FL 33014

SEP / JRB / RSM	DATE	SCALE	SHEET
APPROVED	01/10/97	SHOWN	3
		98001	7

MAXIMUM IMPACT STORM PANEL

24 ga. STEEL

DESIGN PRESSURE	PANEL SPAN
21.93	142"
25.51	139"
29.99	136"
35.36	132"
37.44	130"
39.10	129"
40.77	127"
44.40	124"
47.81	123"
51.23	119"
58.06	112"
61.47	109"
66.85	104"
71.46	100"
75.30	95"
81.45	88"
86.83	82"
91.44	78"

USE 59.5 P.S.F. COLUMN AND 124" PANEL SPAN ON ANCHOR SCHEDULE FOR ANCHOR SPACING FOR SPANS OVER 124"

THE METALTECH STORM PANELS MAY BE INSTALLED WITH OR WITHOUT THE HORIZONTAL BRACE STRAP. REFER TO PANEL DEFLECTION CHARTS.

**.031 STEEL MAXIMUM IMPACT STORM PANEL**

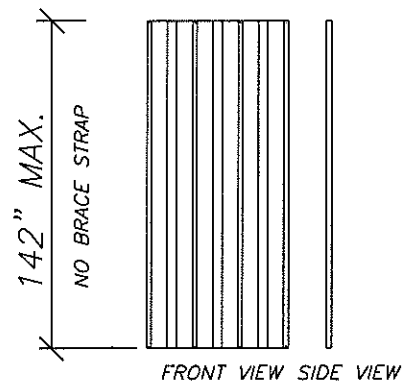

**142" MAX. PANEL HEIGHT  
NO PANEL STRAP  
IS REQUIRED**

HIGH VELOCITY HURRICANE ZONE  
PANEL DEFLECTION CHART  
WITHOUT HORIZONTAL STRAP

PANEL HEIGHT	0"-90"	90"-142"
WALL MOUNT	2 5/8"	3 1/2"
INSIDE MOUNT	2 5/8"	3 1/2"
BUILD OUT	2 5/8"	3 1/2"

MINIMUM DISTANCE BETWEEN GLASS AND PANEL

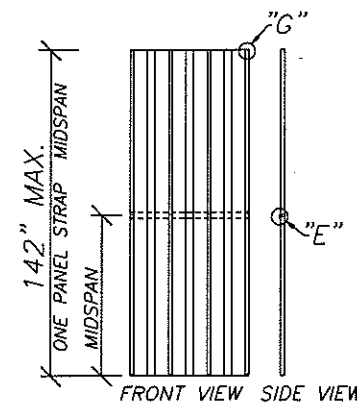

**142" MAX. PANEL HEIGHT  
ONE PANEL STRAP  
LOCATED MIDSPAN**

HIGH VELOCITY HURRICANE ZONE  
PANEL DEFLECTION CHART  
WITH HORIZONTAL STRAP

PANEL HEIGHT	0"-104"	104"-142"
WALL MOUNT	2"	2 1/4"
INSIDE MOUNT	2"	2 1/4"
BUILD OUT	2"	2 1/4"

MINIMUM DISTANCE BETWEEN GLASS AND PANEL

**HORIZONTAL BRACE STRAP**

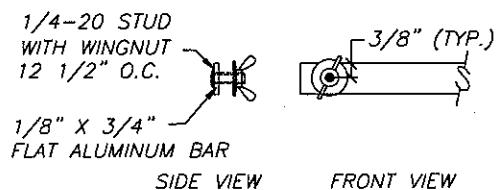

**DETAIL "E"**

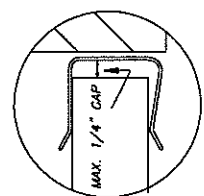

MAXIMUM GAP BETWEEN PANEL AND HEADER IS 1/4" (TYP.)

**DETAIL "F"**

HEADER AND SILL TYPE MAY VARY, DEPENDING ON APPLICATION

DETAIL 13 ON SHEET 3

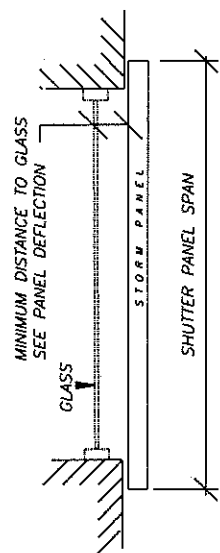

DETAIL 13 ON SHEET 3

DETAIL 3, 4, & 8 ON SHEET 2

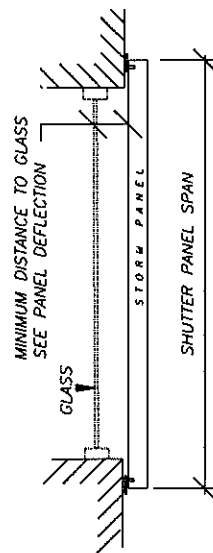

DETAIL 3, 4, & 8 ON SHEET 2

DETAIL 1 ON SHEET 2  
DETAIL 15 ON SHEET 3

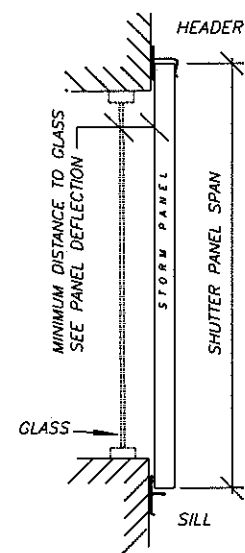

DETAILS 3, 4 AND 8 ON SHEET 2

DETAILS 5, 7, 9, 10 AND 11 ON SHEET 2

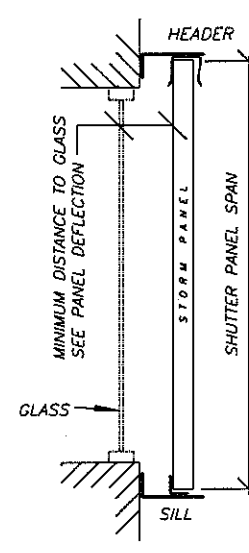

DETAILS 5, 7, 9, 10 AND 11 ON SHEET 2

DETAIL 2 ON SHEET 2  
DETAIL 16 ON SHEET 3

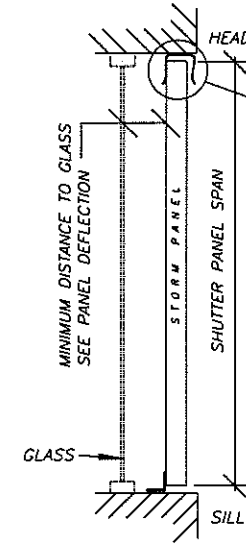

DETAIL 4 ON SHEET 2

**WALL MOUNT**

ANCHORING PANEL TOP & BOTTOM NO HDR. OR SILL

**WALL MOUNT**

ANCHORING PANEL TOP & BOTTOM WITH STUDDED HDR/SILL

**WALL MOUNT**

WITH HDR. AND SILL

**BUILD OUT**

WITH HDR. AND SILL

**INSIDE MOUNT**

WITH HDR. AND SILL

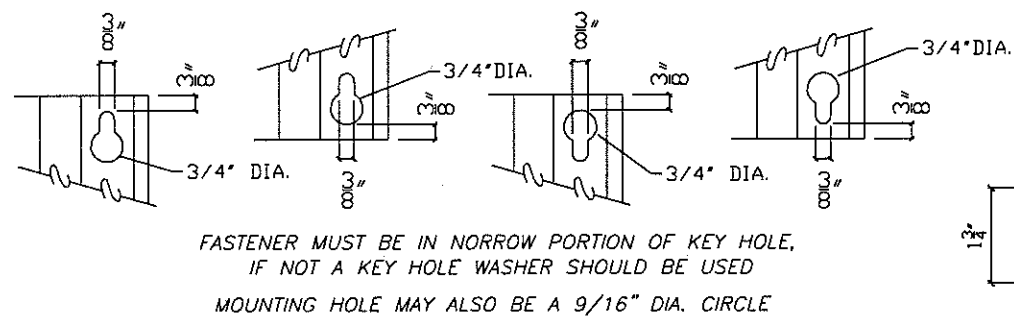

FASTENER MUST BE IN NARROW PORTION OF KEY HOLE, IF NOT A KEY HOLE WASHER SHOULD BE USED  
MOUNTING HOLE MAY ALSO BE A 9/16" DIA. CIRCLE

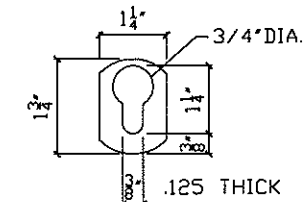

**KEY HOLE WASHER**

**TYPICAL SECTION VIEWS**

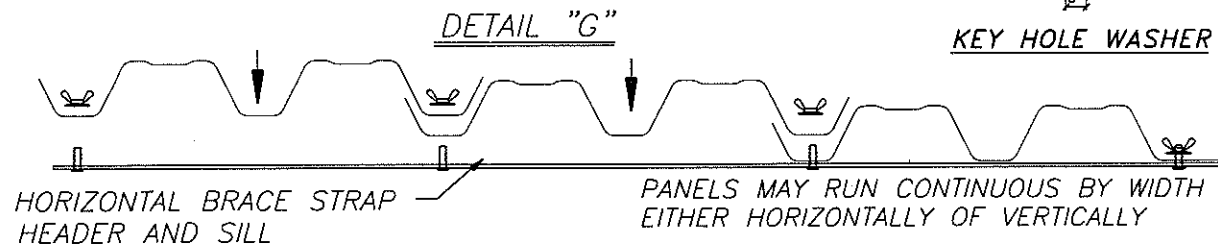

**EXPLODED ASSEMBLY**

PANELS MAY RUN CONTINUOUS BY WIDTH EITHER HORIZONTALLY OR VERTICALLY

ROBERT S. MONSOUR, PE  
EB-0006024  
RAMMS ENGINEERING, INC.

PRODUCT REVISED as complying with the Florida Building Code  
Acceptance No 17-1114-18  
Expiration Date 03/22/22  
By Heba A. M...  
Miami Dade Product Control

BUILDING CODE COMPLIANCE



REVISIONS	BY
03/20/98	SP
12/04/00	SP
01/17/01	SP
09/09/02	SP
01/16/14	SP

RAMMS ENGINEERING, INC.  
Structural Design  
2100 W. 76th STREET, SUITE 311  
HIALEAH, FLORIDA 33016  
EB 0006024

MAXIMUM IMPACT .031 STEEL STORM PANEL  
**SHUTTER-TECH, INC.**  
7485 W. SECOND CT. HIALEAH, FL 33014

DATE	BY
01/10/98	SEP/JRB
03/22/22	APPROVED
03/22/22	DATE
98001	SCALE
	SHOWN
4	98001
7	SHEET

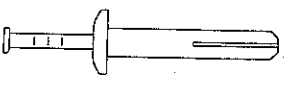
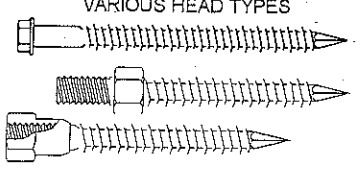
# ANCHOR SCHEDULE

ANCHOR SPACING vs DESIGN PRESSURE AND CONNECTION TYPE			UP TO 59.6 PSF										UPTO 71.5 PSF									
			POURED CONCTETE					CONCRETE BLOCK					POURED CONCTETE					CONCRETE BLOCK				
			CONNECTION TYPE					CONNECTION TYPE					CONNECTION TYPE					CONNECTION TYPE				
ANCHOR TYPE	PANEL	E.D.	A	B	C	D	E	A	B	C	D	E	A	B	C	D	E	A	B	C	D	E
 1/4" RAWL LOK/BOLT (SLEEVE ANCHOR) 1 1/8" MIN. EMBEDMENT	68" SPAN	3"	16	13	8	13	13	16	13	10	13	13	16	13	7	13	13	16	13	8	13	13
		2"	16	13	7	13	13	16	13	8	13	13	16	13	5	13	13	16	13	6	13	13
		1 1/4"	16	13	5	13	13	16	13	6	13	13	14	13	4	13	13	14	13	4	13	13
	88" SPAN	3"	16	13	6	13	13	16	13	7	13	13	14	6	5	9	10	14	6	6	9	10
		2"	15	11	5	13	13	15	11	6	13	13	12	6	4	8	9	12	6	5	8	9
		1 1/4"	13	10	4	13	13	13	10	5	13	13	11	5	3	7	8	11	5	4	7	8
	105" span	3"	14	6	5	9	10	14	7	6	9	10	11	4	4	5	4	12	4	5	5	4
		2"	12	6	4	8	9	12	6	5	8	9	10	4	4	5	4	10	4	4	5	4
		1 1/4"	11	5	3	7	8	11	5	4	7	8	9	3	3	4	4	9	3	3	4	4
	123" span	3"	11	4	4	5	4	12	4	5	5	4										
		2"	10	4	4	5	4	10	4	4	5	4										
		1 1/4"	9	3	3	4	3	9	3	3	4	3										
 1/4" RAWL ZAMAC NAILIN DRIVE (HAMMER DRIVE) 1 3/8" MIN. EMBEDMENT IN CONCRETE 1 1/4" MIN. EMBEDMENT IN BLOCK	68" SPAN	3"	16	13	7	13	13	13	13	6	13	13	15	13	6	13	13	11	11	5	11	11
		2"	15	13	6	13	13	12	12	5	12	12	13	13	5	13	13	10	10	4	10	10
		1 1/4"	14	13	5	13	13	10	10	4	10	10	12	12	4	12	12	9	9	3	9	9
	88" SPAN	3"	13	10	6	13	13	10	8	5	10	10	11	5	5	7	8	8	4	4	5	6
		2"	12	9	5	12	12	9	7	4	9	9	10	5	4	6	7	7	3	3	5	5
		1 1/4"	11	8	4	11	11	8	6	3	8	8	9	4	3	6	6	7	3	3	4	5
	105" span	3"	11	5	5	7	8	8	4	4	5	6	9	3	4	4	3	7	3	3	4	3
		2"	10	5	4	7	7	7	4	3	5	6	8	3	3	4	3	6	3	3	3	3
		1 1/4"	9	4	3	6	7	7	3	3	4	5	8	3	3	4	3	6	3	3	3	3
	123" span	3"	9	3	4	4	3	7	3	3	3	3										
		2"	8	3	3	4	3	6	3	3	3	3										
		1 1/4"	8	3	3	4	3	6	3	3	3	3										
 VARIOUS HEAD TYPES (MASONRY SCREWS) 1/4" RAWL PERMA-SEAL TAPPER 1/4" ELCO PANEL MATES 1 1/2" MIN. EMBEDMENT IN CONCRETE 1 1/4" MIN. EMBEDMENT IN BLOCK	68" SPAN	3"	16	13	11	13	13	16	13	7	13	13	16	13	9	13	13	13	13	6	13	13
		2"	16	13	9	13	13	14	13	6	13	13	16	13	8	13	13	12	12	5	12	12
		1 1/4"	16	13	8	13	13	13	13	5	13	13	16	13	6	13	13	10	10	4	10	10
	88" SPAN	3"	16	13	9	13	13	12	9	5	12	12	16	8	7	11	12	10	5	4	6	7
		2"	16	13	7	13	13	11	8	4	11	11	15	7	6	10	11	9	4	4	6	6
		1 1/4"	16	13	6	13	13	10	7	4	10	10	14	7	5	9	10	8	4	3	5	6
	105" span	3"	16	8	7	11	13	10	5	4	7	8	15	5	6	7	5	8	3	4	4	3
		2"	16	7	6	10	12	9	4	4	6	7	13	5	5	6	5	8	3	3	4	3
		1 1/4"	14	7	5	9	10	8	4	3	5	6	12	4	4	5	4	7	3	3	3	3
	123" span	3"	15	5	6	7	5	8	3	4	4	3										
		2"	13	5	5	6	5	8	3	3	4	3										
		1 1/4"	12	4	4	5	4	7	3	3	3	3										
 1/4-20 x 7/8", 1/2" DIA. RAWL CALK-IN (MACHINE SCREW ANCHOR) 7/8" MIN. EMBEDMENT	68" SPAN	3"	16	13	12	13	13	16	13	7	13	13	16	13	10	13	13	13	13	6	13	13
		2.5"	16	13	10	13	13	14	13	6	13	13	16	13	9	13	13	12	12	5	12	12
		2"	16	13	8	13	13	13	13	5	13	13	16	13	7	13	13	10	10	4	10	10
	88" SPAN	3"	16	13	9	13	13	12	9	5	12	12	16	10	8	13	13	10	5	4	6	7
		2.5"	16	13	8	13	13	11	8	5	11	11	16	9	7	12	13	9	4	4	6	6
		2"	16	13	6	13	13	10	7	4	10	10	16	8	5	11	12	8	4	3	5	6
	105" span	3"	16	10	8	13	13	10	5	4	7	8	16	6	7	8	3	8	3	4	4	3
		2.5"	16	9	7	13	13	9	4	4	6	7	16	6	6	8	3	8	3	3	4	3
		2"	16	8	5	11	13	8	4	3	5	6	14	5	4	7	3	7	3	3	3	3
	123" span	3"	16	6	7	8	7	8	3	4	4	3										
		2.5"	16	6	6	8	6	8	3	3	4	3										
		2"	14	5	4	7	5	7	3	3	3	3										

NOTES:

SPANS AND LOADS SHOWN IN THIS SCHEDULE ARE FOR DETERMINING ANCHOR SPACING ONLY. FOR ALLOWABLE SPANS VS. DESIGN LOADS REFER TO SHEET 4.

MINIMUM EMBEDMENT AND EDGE DISTANCE EXCLUDES STUCCO AND/OR WALL FINISHES.

SHADED AREAS REPRESENT ANCHOR CONDITIONS THAT ARE NOT ACCEPTABLE.

IT SHALL BE THE RESPONSIBILITY OF THE CONTRACTOR TO VERIFY THE SOUNDNESS OF THE STRUCTURE TO WITH STAND THE ADDITIONAL LOADS AND INSURE PROPER ANCHORAGE. SHUTTER SYSTEM MAY BE INTSALL INTO WOOD, CONCRETE OR MASONRY.

REVISIONS	BY
03/20/98	SP
12/15/00	SP
01/17/01	SP
01/05/06	SP
01/16/14	SP

RAMS ENGINEERING, INC.  
*Structural Design*  
 2100 W. 76th STREET, SUITE 311  
 HIALEAH, FLORIDA 33015  
 EB 0006024

MAXIMUM IMPACT .031 STEEL STORM PANEL  
**SHUTTER-TECH, INC.**  
 7485 W. SECOND CT., HIALEAH, FL 33014

BUILDING CODE COMPLIANCE

*Monsour*  
9/11/17

ROBERT S. MONSOUR, PE  
 EB-0006024  
 RAMS ENGINEERING, INC.

PRODUCT REVISED  
 as complying with the Florida:  
 Building Code  
 Acceptance No 17-114-18  
 Expiration Date 03/22/22  
 By *HegA.M*  
 Miami Data Product Control

DATE	SCALE	SHEET
SEP/JRB	01/10/98	98001
	SHOWN	
	5	7

# ANCHOR SCHEDULE

ANCHOR SPACING vs DESIGN PRESSURE AND CONNECTION TYPE			UP TO 81.5 PSF										UPTO 91.4 PSF									
			POURED CONCTETE					CONCRETE BLOCK					POURED CONCTETE					CONCRETE BLOCK				
			CONNECTION TYPE					CONNECTION TYPE					CONNECTION TYPE					CONNECTION TYPE				
ANCHOR TYPE	PANEL	E.D.	A	B	C	D	E	A	B	C	D	E	A	B	C	D	E	A	B	C	D	E
	68" SPAN	3"	15	10	6	13	13	16	10	7	13	13	13	7	5	9	11	13	7	6	9	11
		2"	14	9	5	13	13	14	9	6	13	13	12	6	4	8	9	12	6	5	8	10
		1 1/4"	12	8	4	12	12	12	8	4	12	12	11	5	3	7	9	11	5	4	7	9
	88" SPAN	3"	12	4	5	6	5	12	5	5	6	5	11	3	4	5	3	11	4	5	5	3
		2"	11	4	4	5	4	11	4	4	5	5	9	3	3	4	3	10	3	4	4	3
		1 1/4"	10	4	3	5	4	10	4	3	5	4	9	3	3	4	3	9	3	3	4	3
	105" span	3"																				
		2"																				
		1 1/4"																				
	123" span	3"																				
		2"																				
		1 1/4"																				
	68" SPAN	3"	13	8	5	12	13	9	6	4	9	9	11	5	5	8	9	8	4	4	6	7
		2"	11	7	5	11	11	8	5	4	8	8	10	5	4	7	8	8	4	3	5	6
		1 1/4"	10	7	4	10	10	8	5	3	7	8	9	4	3	6	7	7	3	3	4	5
	88" SPAN	3"	10	4	4	5	4	7	3	3	4	3	9	3	4	4	3	7		3	3	
		2"	9	3	3	4	4	7	3	3	3	3	8	3	3	3		6		3		
		1 1/4"	8	3	3	4	3	6			3		7		3	3		5				
	105" span	3"																				
		2"																				
		1 1/4"																				
	123" span	3"																				
		2"																				
		1 1/4"																				
	68" SPAN	3"	16	13	8	13	13	11	7	5	11	11	16	8	7	12	13	10	5	4	7	8
		2"	16	11	7	13	13	10	6	4	10	10	16	8	6	10	12	9	4	4	6	7
		1 1/4"	16	10	6	13	13	9	6	3	9	9	14	7	5	9	11	8	4	3	5	6
	88" SPAN	3"	15	6	6	8	6	9	3	4	4	4	14	4	6	6	4	8	3	3	3	3
		2"	14	5	5	7	6	8	3	3	4	3	12	4	5	5	4	7		3	3	
		1 1/4"	12	5	4	6	5	7	3	3	4	3	11	4	4	5	3	6			3	
	105" span	3"																				
		2"																				
		1 1/4"																				
	123" span	3"																				
		2"																				
		1 1/4"																				
	68" SPAN	3"	16	13	9	13	13	11	7	5	11	11	16	10	8	13	13	10	5	4	7	8
		2.5"	16	13	7	13	13	10	7	4	10	10	16	9	7	13	13	9	4	4	6	7
		2"	16	12	6	13	13	9	6	3	9	9	16	8	5	12	13	8	4	3	5	6
	88" SPAN	3"	16	7	7	9	8	9	3	4	4	4	16	5	6	7	5	8	3	3	3	3
		2.5"	16	6	6	8	7	8	3	3	4	3	15	5	5	6	5	7		3	3	
		2"	15	6	4	8	6	7	3	3	4	3	13	4	4	6	4	6			3	
	105" span	3"																				
		2.5"																				
		2"																				
	123" span	3"																				
		2.5"																				
		2"																				

**NOTES:**

SPANS AND LOADS SHOWN IN THIS SCHEDULE ARE FOR DETERMINING ANCHOR SPACING ONLY. FOR ALLOWABLE SPANS VS. DESIGN LOADS REFER TO SHEET 4.

MINIMUM EMBEDMENT AND EDGE DISTANCE EXCLUDES STUCCO AND/OR WALL FINISHES.

SHADED AREAS REPRESENT ANCHOR CONDITIONS THAT ARE NOT ACCEPTABLE.

IT SHALL BE THE RESPONSIBILITY OF THE CONTRACTOR TO VERIFY THE SOUNDNESS OF THE STRUCTURE TO WITH STAND THE ADDITIONAL LOADS AND INSURE PROPER ANCHORAGE. SHUTTER SYSTEM MAY BE INTSALL INTO WOOD, CONCRETE OR MASONRY.

REVISIONS	BY
03/20/98	SP
01/17/01	SP
01/05/06	SP
01/16/14	SP

**RAMMS ENGINEERING, INC.**  
*Structural Design*  
 2100 W. 76th STREET, SUITE 311  
 HIALEAH, FLORIDA 33016  
 EB 0006024

MAXIMUM IMPACT .031 STEEL STORM PANEL  
**SHUTTER-TECH, INC.**  
 7485 W. SECOND CT. HIALEAH, FL 33014



BUILDING CODE COMPLIANCE

**ROBERT S. MONSOUR, PE**  
 EB-0006024  
 RAMMS ENGINEERING, INC.

PRODUCT REVISED  
 as complying with the Florida  
 Building Code  
 Acceptance No. 17-1114-18  
 Expiration Date 03/22/22  
 By Heidi A. Nelson  
 Miami Design Product Control

DATE	APPROVED
SEP/JRB/RSM	
DATE: 01/10/98	
SCALE: SHOWN	
JOB: 98001	
SHEET: 6	
	7

# ANCHOR SCHEDULE

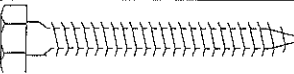
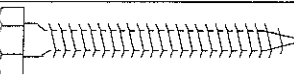
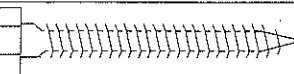
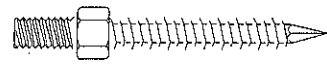
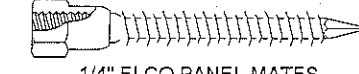
WOOD APPLICATIONS			UP TO 59.5 PSF					UP TO 71.5 PSF					UP TO 81.5 PSF					UP TO 91.4 PSF				
ANCHOR TYPE	DIA.	SPAN	CONNECTION TYPE					CONNECTION TYPE					CONNECTION TYPE					CONNECTION TYPE				
			A	B	C	D	E	A	B	C	D	E	A	B	C	D	E	A	B	C	D	E
 BRASS WOOD BUSHING 1" MIN. PENETRATION	1/4-20	68" SPAN	14	13	5	13	13	12	12	5	12	12	10	7	4	10	10	9	4	4	6	7
		88" SPAN	11	8	4	11	11	9	4	3	6	7	8	3	3	4	3	7		3	3	
		105" SPAN	9	4	4	6	7	8	3	3	4	3										
		123" SPAN	8	3	3	4	3															
 WOOD LAGS 1" MINIMUM TREAD PENETRATION	1/4"	68" SPAN	16	13	8	13	13	15	13	6	13	13	14	9	6	13	13	12	6	5	8	9
		88" SPAN	14	11	6	13	13	12	6	5	8	9	10	4	4	5	4	9	3	4	4	3
		105" SPAN	12	6	5	8	9	10	4	4	5	4										
		123" SPAN	10	4	3	5	4															
 WOOD LAGS 1" MINIMUM TREAD PENETRATION	5/16"	68" SPAN	16	13	10	13	13	16	13	8	13	13	16	10	7	13	13	14	7	6	9	11
		88" SPAN	16	13	7	13	13	14	7	6	9	10	12	5	5	6	5	11	4	5	5	3
		105" SPAN	14	7	6	9	10	12	4	5	6	4										
		123" SPAN	12	4	5	6	4															
 WOOD LAGS 1" MINIMUM TREAD PENETRATION	3/8"	68" SPAN	16	13	11	13	13	16	13	9	13	13	16	12	8	13	13	16	8	7	11	13
		88" SPAN	16	13	9	13	13	16	8	7	10	12	14	5	6	7	6	13	4	6	5	4
		105" SPAN	16	8	7	11	12	14	5	6	6	5										
		123" SPAN	13	5	6	6	5															
 WOOD LAGS 1" MINIMUM TREAD PENETRATION	7/16	68" SPAN	16	13	12	13	13	16	13	10	13	13	16	13	9	13	13	16	9	8	12	13
		88" SPAN	16	13	9	13	13	16	8	8	12	13	16	6	7	8	7	14	5	6	6	4
		105" SPAN	16	9	8	12	13	15	5	7	7	6										
		123" SPAN	15	5	7	7	6															
 1/4" ELCO PANEL MATES 1 7/8" MIN. THREAD PENETRATION	1/4"	68" SPAN	16	13	8	13	13	15	13	6	13	13	14	9	6	13	13	12	6	5	8	9
		88" SPAN	14	11	6	13	13	12	6	5	8	9	10	4	4	5	4	9	3	4	4	3
		105" SPAN	12	6	5	8	9	10	4	4	5	4										
		123" SPAN	10	4	3	5	4															
 VERIOUS HEAD TYPES 1/4" MASONRY SCREWS 1 7/8" MIN. THREAD PENETRATION	1/4"	68" SPAN	16	13	8	13	13	15	13	6	13	13	14	9	6	13	13	12	6	5	8	9
		88" SPAN	14	11	6	13	13	12	6	5	8	9	10	4	4	5	4	9	3	4	4	3
		105" SPAN	12	6	5	8	9	10	4	4	5	4										
		123" SPAN	10	4	3	5	4															

**NOTES:**

SPANS AND LOADS SHOWN IN THIS SCHEDULE ARE FOR DETERMINING ANCHOR SPACING ONLY. FOR ALLOWABLE SPANS VS. DESIGN LOADS REFER TO SHEET 4.

WHEN ANCHORING TO WOOD, THE WOOD MUST BE A MINIMUM 2 X 4 EQUAL TO #2 SOUTHERN PINE 0.55 SPECIFIC GRAVITY AND STRUCTURALLY PART OF THE FRAMING STRUCTURE OR SUCURELY ATTACHED TO FRAMING STRUCTURE

SHADED AREAS REPRESENT ANCHOR CONDITIONS THAT ARE NOT ACCEPTABLE.

IT SHALL BE THE RESPONSIBILITY OF THE CONTRACTOR TO VERIFY THE SOUNDNESS OF THE STRUCTURE TO WITH STAND THE ADDITIONAL LOADS AND INSURE PROPER ANCHORAGE. SHUTTER SYSTEM MAY BE INTSALL INTO WOOD, CONCRETE OR MASONRY.

  
**ROBERT S. MONSOUR, PE**  
**EB-0006024**  
 RAMMS ENGINEERING, INC.

PRODUCT REVISED  
 as complying with the Florida  
 Building Code  
 Acceptance No 17-114.18  
 Expiration Date 03/22/22  
 By Heg A. Mc  
 Miami Dept. Product Control

BUILDING CODE COMPLIANCE

REVISIONS	BY
08/14/98	SP
01/17/01	SP
01/05/06	SP
01/16/14	SP

**RAMMS ENGINEERING, INC.**  
*Structural Design*  
 2100 W. 76th STREET, SUITE 311  
 HIALEAH, FLORIDA 33016  
 EB 0006024

MAXIMUM IMPACT .031 STEEL STORM PANEL  
**SHUTTER-TECH, INC.**  
 7485 W. SECOND CT. HIALEAH, FL 33014

DATE	APPROVED
01/10/98	SEP/JRB/RSM
SCALE	SHOWN
JOB	98001
SHEET	7